

User Manual

Revision 1a

Phoenix Analysis & Design Technologies, Inc. (PADT, Inc.)

TEL : 1-800-293-PADT FAX : 480-813-4884

support@DimensionSCA.com

www.DimensionSCA.com

This page left intentionally blank

Table of Contents

1: QUICK START GUIDE	4
2: IMPORTANT SAFEGUARDS	6
3: SAFETY WARNINGS	7
4: WARRANTY INFORMATION	8
5: UNDERSTANDING YOUR SCA	9
5.2: KEY COMPONENTS	9
5.3: ASSEMBLY DRAWING	13
6: UNPACKING, INSPECTING AND INSTALLING YOUR SCA	14
6.1: PACKAGE CONTENTS	14
6.2: UNPACKING	14
6.3: INSPECT UNIT	14
6.4: INSTALLATION.....	14
7: OPERATING YOUR SCA	15
7.1: LOCATING THE UNIT.....	15
7.2: FILL THE UNIT WITH WATER	15
7.3: ADD CLEANING CONCENTRATE TO THE TANK	15
7.4: CONNECT THE UNIT TO POWER	15
7.5: TURN THE UNIT ON	16
7.6: PLACE PARTS IN UNIT FOR CLEANING	16
7.7: ADJUST LIQUID LEVEL BEFORE CLEANING AND TEST LEVEL SENSORS	16
7.8: PLACE LID ON TANK.....	16
7.9: SET SYSTEM TIMER	17
7.10: START REMOVAL CYCLE	17
7.11: MONITOR CLEANING CYCLE	17
7.12: REMOVE PARTS FROM THE UNIT	18
7.13: TURN UNIT OFF	18
8: MAINTAINING YOUR SCA	19
8.1: COOLING THE TANK LIQUID	19
8.2: DRAINING THE TANK.....	19
8.3: REFILLING THE TANK	19
8.4: INSPECTING AND CLEANING STRAINER	19
8.5: CLEANING	20
8.6: MOVING	20
8.7: REPLACING THE FUSE.....	20
9: TROUBLESHOOTING	21
10: TECHNICAL SPECIFICATIONS	24
11: TECHNICAL SUPPORT	25
11.1: REPLACEMENT PARTS	25

1: Quick Start Guide

1: VERIFY PROPER INSTALLATION

Inspect unit and its placement and verify that the unit is still installed properly. Review the installation portion of this manual if needed.

2: REVIEW SAFETY INFORMATION

Inspect unit and verify that all safety guidelines are being followed. Review the safety reminder portion of this manual if needed.

Never place your face near the tank when removing the lid, fumes from the cleaning solution may cause eye and respiratory irritation.

Always wear protective gloves and proper eye protection when working with the cleaning solution in the SCA.

3: FILL TANK TO LEVEL WITH WARM WATER

Verify that the drain valve is in the closed position. With the basket in place, fill the tank to just below the Guide/Support pins in the tank. (About 8Gal/31L) Fill with water only. For the initial fill, it is highly recommended that warm water be used to reduce warm up time. The liquid level must be above the liquid level low marks on the large basket or tank back wall.

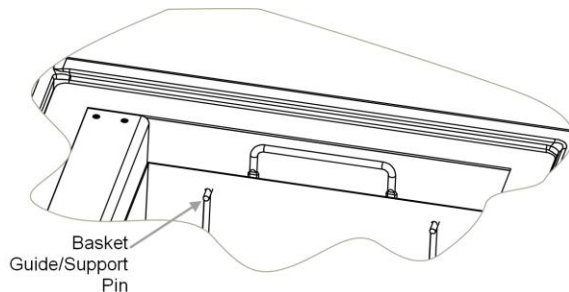

4: ADD 850-GRAMS OF WATERWORKS P400SC CONCENTRATE

WEARING PROTECTIVE GLOVES AND PROPER EYE PROTECTION, carefully and slowly add in 850 grams (roughly 4/5 of a bottle) of WaterWorks Soluble Concentrate P400SC into the water.

5: ADD PARTS

Add larger parts directly into solution. Use smaller square basket for smaller parts that might be damaged if left to float around in the tank.

6: PLUG IN UNIT

Securely plug the supplied power cord into the receptacle in the rear of the unit and then into a grounded power outlet. The plug is a disconnecting device and should be easily accessible at all times. Only use a power cord provided by the manufacturer.

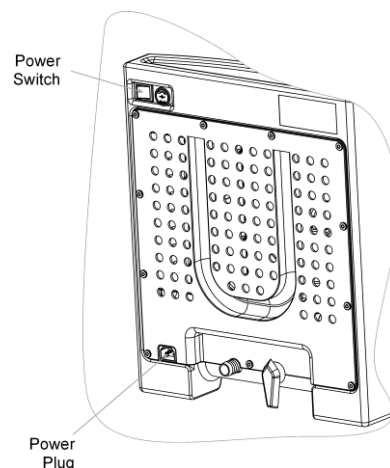

7: SWITCH UNIT ON

Press rocker switch on the back of unit.

8: FOLLOW INDICATOR LIGHTS

If any of the liquid level lights are illuminated, continue to adjust solution (adding to or subtracting water from inner tank) until both lights are off.

9: PLACE TANK LID ON UNIT

For safety and efficiency reasons, it is important to leave the lid on the unit when it is operating.

10: SET COUNTDOWN TIMER

Set the timer, the left side of the control display, by first pressing the SET button and pressing the up and down arrows to increase and decrease the number of minutes. Press the SET button again and set the number of hours using the same up and down arrows.

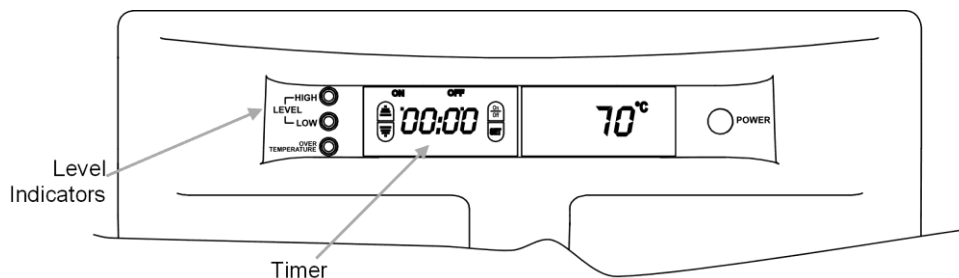

11: START SUPPORT REMOVAL

When the proper time is set, press the On/Off button to engage the pump and heater. The system is now fully powered ON.

12: REMOVE PARTS

Remove the parts by putting on protective gloves, removing the lid and lifting the cage up and resting it on the Support/Guide pins.

Never place your face near the tank when removing the lid, vapors from the cleaning solution may cause eye and respiratory irritation.

Let the fluid drain off of the parts for a few minutes then remove them, wash off any remaining liquid, and dry them with a clean towel or paper towels.

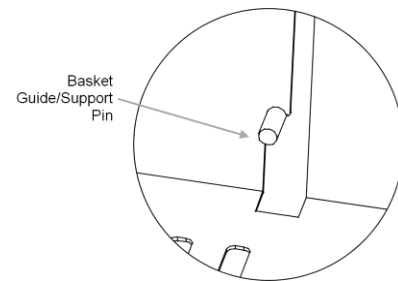

13: TURN OFF UNIT

To turn off the unit, press the rocker switch on the upper left corner of the back panel to the off position.

14: DRAIN UNIT

To drain the unit, remove the drain hose from the storage space on the back of the unit and place it on the end of the drain tube. Place the other end of the hose in a drain or in a stainless steel or plastic container. Turn the drain valve to the open position. Make sure it is in the closed position when you are done and then remove and store the hose.

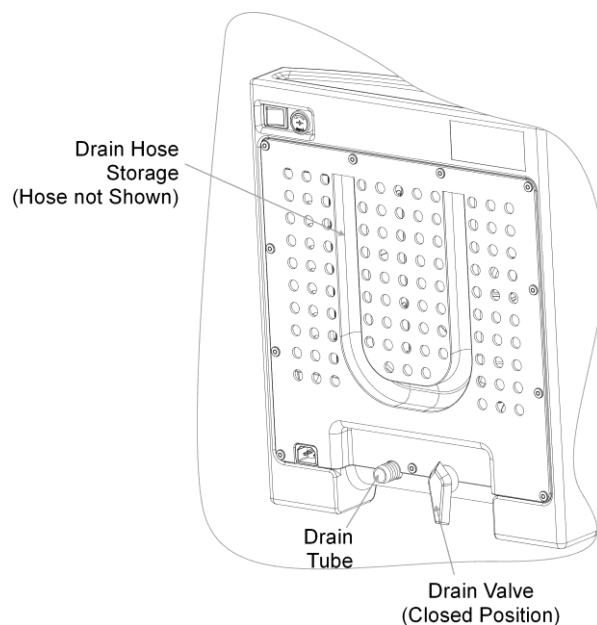

2: Important Safeguards

These notes are intended to draw your attention to risks which only you can recognize and avoid or overcome. They are intended to enhance your own safety consciousness.

THE CORRECT UNIT USAGE AND PROPER HANDLING IS SOLELY THE USER'S RESPONSIBILITY.

Failure to follow these safeguards and/or common sense may result in significant personal injury and will void the warranty.

The solution added to the unit to aid in support removal contains Sodium Hydroxide. Please read and remember the following safety information about this material:



DANGER: SOLUTE CONTAINS SODIUM HYDROXIDE WHICH CAN CAUSE SEVERE BURNS TO EYES, SKIN AND RESPIRATORY TRACT.

Do not get in eyes, on skin or on clothing. Do not swallow or inhale powder. Keep container closed. Use only with adequate ventilation. Wash thoroughly after handling.

First Aid:

In case of contact, immediately flush eyes and skin with plenty of water for at least 15 minutes while removing contaminated clothing and shoes. Get medical attention immediately.

NFPA Rating:	Health	H=3
	Flammability	F=0
	Reactivity	R=1

3: Safety Warnings



READ ALL INSTRUCTIONS BEFORE OPERATING



WHAT TO DO

- Always wear thermal gloves and safety glasses when working near the unit or when touching any part of the unit.
- Always keep this manual near the unit.
- Always assume that the unit is hot and always wear proper thermal gloves when working with or around the unit.
- Always place unit on a flat, stable surface.
- Always wipe away any cleaning solution spilled near the control panel.
- Always locate the unit away from locations where it might be bumped.
- Always unplug the unit from the wall when it is not in use.
- Always use the power cord supplied by the manufacturer.
- Always make sure that the power plug receptacle is easily accessible.
- Always unplug the unit from the wall when it is being cleaned, moved or serviced in any way.
- Always connect the device to a power receptacle with a protective ground.
- Always change the cleaning liquid as recommended in this manual.
- Always clean the unit with mild soap and a sponge or rag. Rinse tank completely before refilling.
- Always stand upright with your head away from the tank when opening the lid to avoid vapors.
- Always remove liquid from the tank before adding large parts to avoid overflow.
- Always operate the unit in a well ventilated location.
- Always operate within environmental temperature range of 10 to 35 degree C.

WHAT NOT TO DO

- Do not use the SCA for any purpose other than removing SST support material from parts created on Stratasys Dimension 3D Printers.
- Do not allow aluminum, zinc or acids to come into contact with the cleaning solution. The cleaning solution used in this unit contains Sodium Hydroxide.
- Do not use any liquid other than water and the Stratasys supplied cleaning solution in the unit.
- Do not add more than the recommended amount of cleaning solution to the unit.
- Do not overfill the unit.
- Do not allow the fluid temperature to exceed 70°C(160°F).
- Do not clean the unit with solvents.
- Do not immerse the unit in liquid of any kind.
- Do not operate the device if there are *any* doubts regarding safe operation due to the outer appearance (e.g. damages) of the system or the operating environment.
- Do not operate the unit until you have read this manual and understand all aspects of the unit's operation.
- Do not move the unit until you are certain that it is cool and all liquid has been drained from the unit.
- Do not operate the unit unless the water level is above the liquid level low indicator on the large part basket or the rear wall of the tank.
- Do not operate the unit dry.

4: Warranty Information

WARRANTY CERTIFICATE

Covering PADT, Inc. Support Cleaning Apparatus

Effective January 1, 2009

One Year Limited Warranty Coverage

All new Support Cleaning Apparatus (SCA) systems are warranted exclusively by PADT, Inc.'s ("Manufacturer") limited warranty as follows:

Each Support Cleaning Apparatus system ("System") and its components ("Components"), except those listed below under limits and exclusions, is warranted against defects in the material and workmanship for a period of one (1) year from the date of installation at the end users ("Customer") facility.

Repair or replacement only: manufacturer's liability under this agreement shall be limited to repairing or replacing, at the discretion of manufacturer, parts, or components sufficient to return the system to conform with the marketing specifications of the system.

Components subject to wear during normal use and over time such as paint, finish, light bulbs, seals, etc., are excluded from this warranty.

This warranty is void if the system is subjected to mishandling, misuse, neglect, accident, improper installation, improper maintenance, or improper operation or application, or if the machine was improperly repaired or serviced by the customer. This warranty is void if the system is not installed by a certified distributor and the proper installation documentation provided by the manufacturer has not been submitted.

Liability, whether based on warranty, negligence or other cause, arising out of and/or incidental to sale, use or operation of the system, or any part thereof, shall not in any case exceed the cost of repair or replacement of the defective equipment, and such repair or replacement shall be the exclusive remedy of the purchaser, and in no case will we be responsible for any and/or all consequential or incidental damages including without limitation, and/or all consequential damages arising out of commercial losses.

This warranty is transferrable from the original end-user to another party if the machine is sold via private sale before the end of the warranty period.

The foregoing is a limited warranty and it is the only warranty by manufacturer. MANUFACTURER DISCLAIMS ALL OTHER WARRANTIES, EXPRESS OR IMPLIED, INCLUDING BUT NOT LIMITED TO ALL WARRANTIES OF MERCHANTABILITY AND FITNESS FOR A PARTICULAR PURPOSE.

5: Understanding your SCA

The Support Cleaning Apparatus (SCA) is a device specifically developed to provide robust and efficient removal of support material from parts created in Dimension 3D printers from Stratasys, Inc. that utilize their Soluble Support Technology (SST). The system was developed with input from Stratasys, users and distributors of SST based systems.

5.1.1: How it Works

The system removes support material by immersing parts created with Stratasys' SST material in a warm bath of water with a specific amount of Sodium Hydroxide added (see operating instructions). The SCA then circulates the heated water around the parts in the tub. The hot, slightly base solution dissolves the support material without harming the underlying model material. Over time, depending on geometry and the amount of support material, all the support material is dissolved and the part is ready to be removed, dried and used for its intended purpose.

5.2: Key Components

The SCA consists of several key components that all users should be familiar with. Understanding the function of each component is important for the safe operation of the system, and will aid in extending the life of your SCA.

5.2.1: Control Area

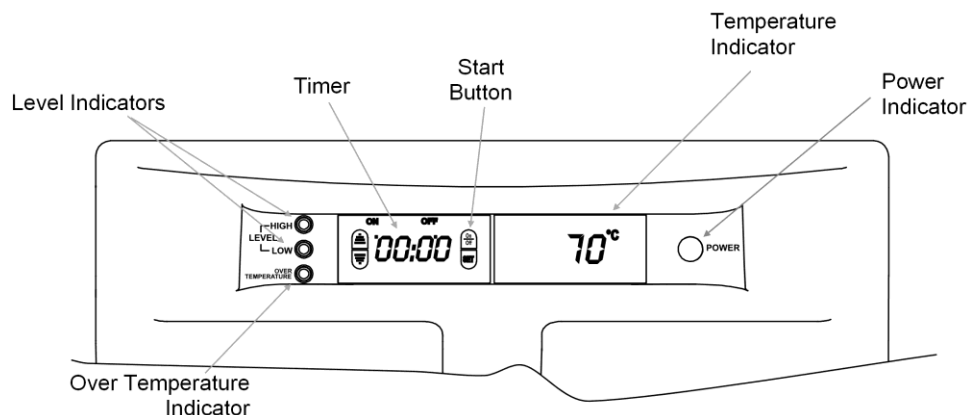

Figure 1: Control Area

The control area provides users with the key feedback they need to safely operate the SCA. It is also where the user can set the timer.

The Level Indicator lights tell the user if the liquid level in the tank is too high or too low. The pump and heater will not operate if either indicator is lit.

The Over Temperature Indicator lights let the user know when the liquid in the system becomes too hot. An alarm will also sound. The pump and heater will not operate if the indicator is lit.

The timer is used to turn on the pump and heater and control how long they run. The user can set the timer using the up and down arrows on the left of the time display. The pump and heater will not operate until the timer is set. Once the proper time is entered, pressing the set button starts the timer. The pump and heater are then turned on, and the timer will begin counting down, when the On/Off button above the set button is pushed. The

system will run until the timer reaches zero or until the level or over temperature indicators are lit.

The temperature indicator shows the current temperature of the liquid in the tank.

The power indicator is lit when the system is powered, even when the pump and heater are not running.

The Warning Buzzer (not shown in figure) will sound if the level or over temperature indicators are lit. The buzzer will shut off after three (3) minutes but the indicators will remain lit until power is shut off or the cause of the alarm is removed.

5.2.2: Tank Area

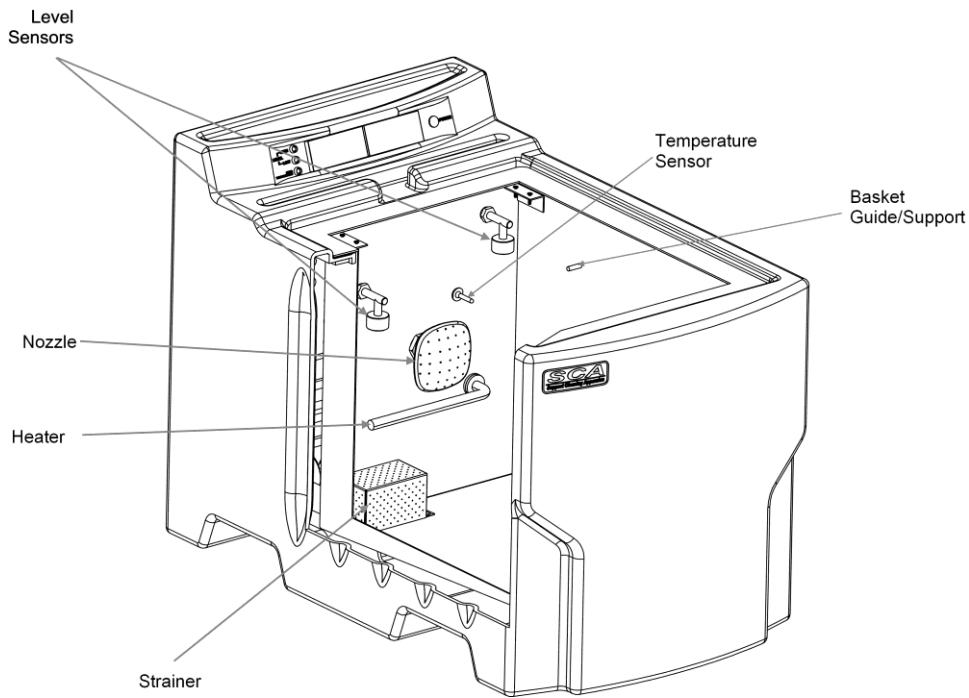

Figure 2: Tank Area

The tank area is used to hold the liquid and it is where the parts are cleaned. The SCA improves part cleaning by circulating the liquid in the tank. There are many important components in the tank.

The Basket Assembly is used to hold parts during cleaning and to lift parts out of the tank. Users should wear thermal gloves when lifting the basket from the tank.

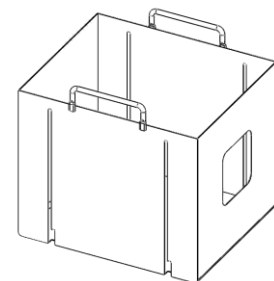

Figure 3: Basket Assembly

The Small Parts Cage is used to hold small parts during cleaning.

The Lid is used to keep the parts in the tank submerged, to avoid spillage of liquid, and to keep hands away from the hot liquid during operation. The lid should be left on top of the tank except when adding or removing parts from the basket. Never place your face near the tank when removing the lid, vapors from the cleaning solution may cause eye and respiratory irritation.

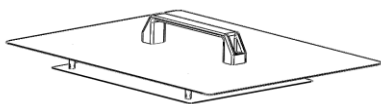

Figure 4: Lid

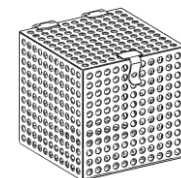

Figure 5: Small Parts Cage

The Strainer keeps particles from getting into the drain and clogging the pump (during operation) or the drain valve (during draining). The user should clean the strainer with tap water when replacing saturated cleaning solution to obtain the best performance. Always wear the proper thermal gloves when reaching into the tank to remove the strainer for cleaning.

The Separator Panel (not shown in figure) is a metal sheet that covers the heater and sensors. The separator panel should never be removed unless the unit is unplugged and completely drained.

The Heater is located behind the Separator Panel and is not visible unless the panel is removed. It heats the water in the tank.

The Nozzle directs the flow of liquid into the tank. The nozzle can be removed for cleaning if the holes are clogged. Simply unscrew the nozzle and rinse with tap water to un-clog holes.

The Temperature and Level sensors are used to sense the height and temperature of the liquid in the tank. They are not visible unless the separator panel is removed.

The basket guide/support pins are used to: 1) guide the basket as it is lowered and raised from the tank, 2) to support the basket when the unit is running so that it does not rest on the bottom of the tank, and 3) to support the basket over the tank when it is raised for part removal.

5.2.3: Back Panel Area

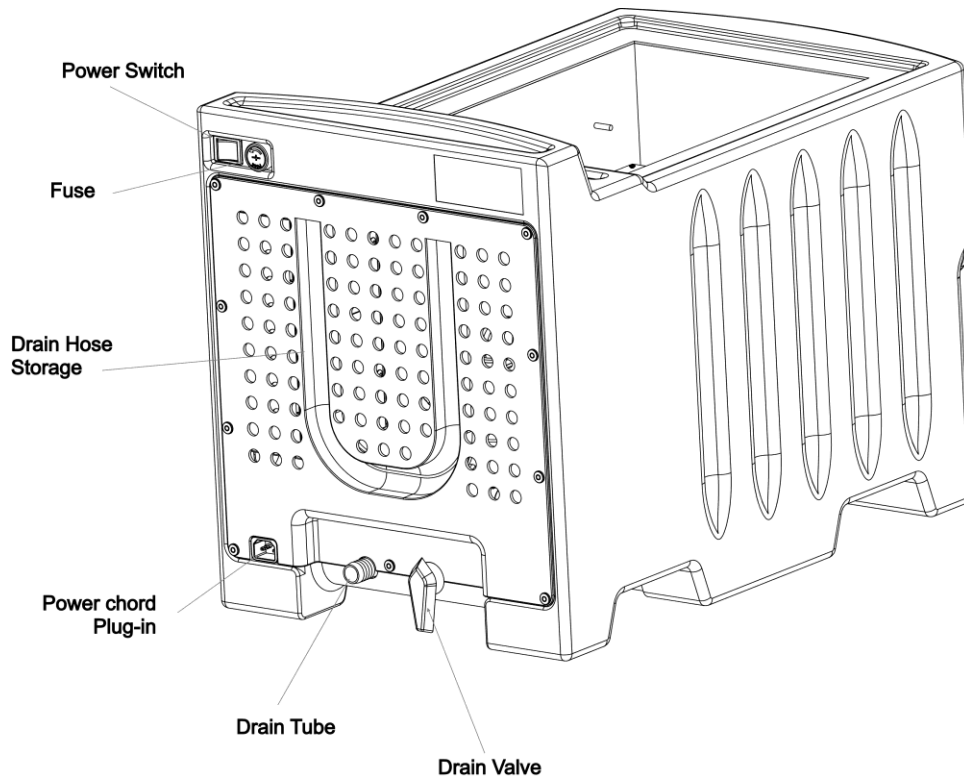

Figure 6: Back Panel Area

The Back Panel area of the system has important power and liquid connections and controls.

The Power Switch controls power to the unit.

The fuse protects the electrical system from overloading and should only be replaced with a new fuse provided by the manufacturer.

The Power Cord (not shown in figure) is used to connect the system to a wall outlet for power. Only use a power cord provided by the manufacturer.

The Power Cord Plug-In is where the power cord is connected to the unit. The plug is a disconnecting device and should be easily accessible at all times.

The tank is drained by placing the included drain hose (not shown in figure) to the Drain Tube and turning the Drain Valve to the open position. The liquid in the tank should be at room temperature and the unit should be turned off and unplugged from the wall before it drained. When not in use, the drain hose may be stored in the U-shaped indentation in the back panel.

5.2.4: Product Identification Tag

The Product Identification tag is placed on the upper right hand of the back panel. It contains key support information for the SCA including Model Number, Serial Number and contact information for support. It should never be tampered with or removed.



Figure 7: Product Identification Tag

5.3: Assembly Drawing

Figure 8 shows the entire SCA assembly. Table 1 lists the key components in the system. Please consult this information when calling for support or ordering replacement parts.

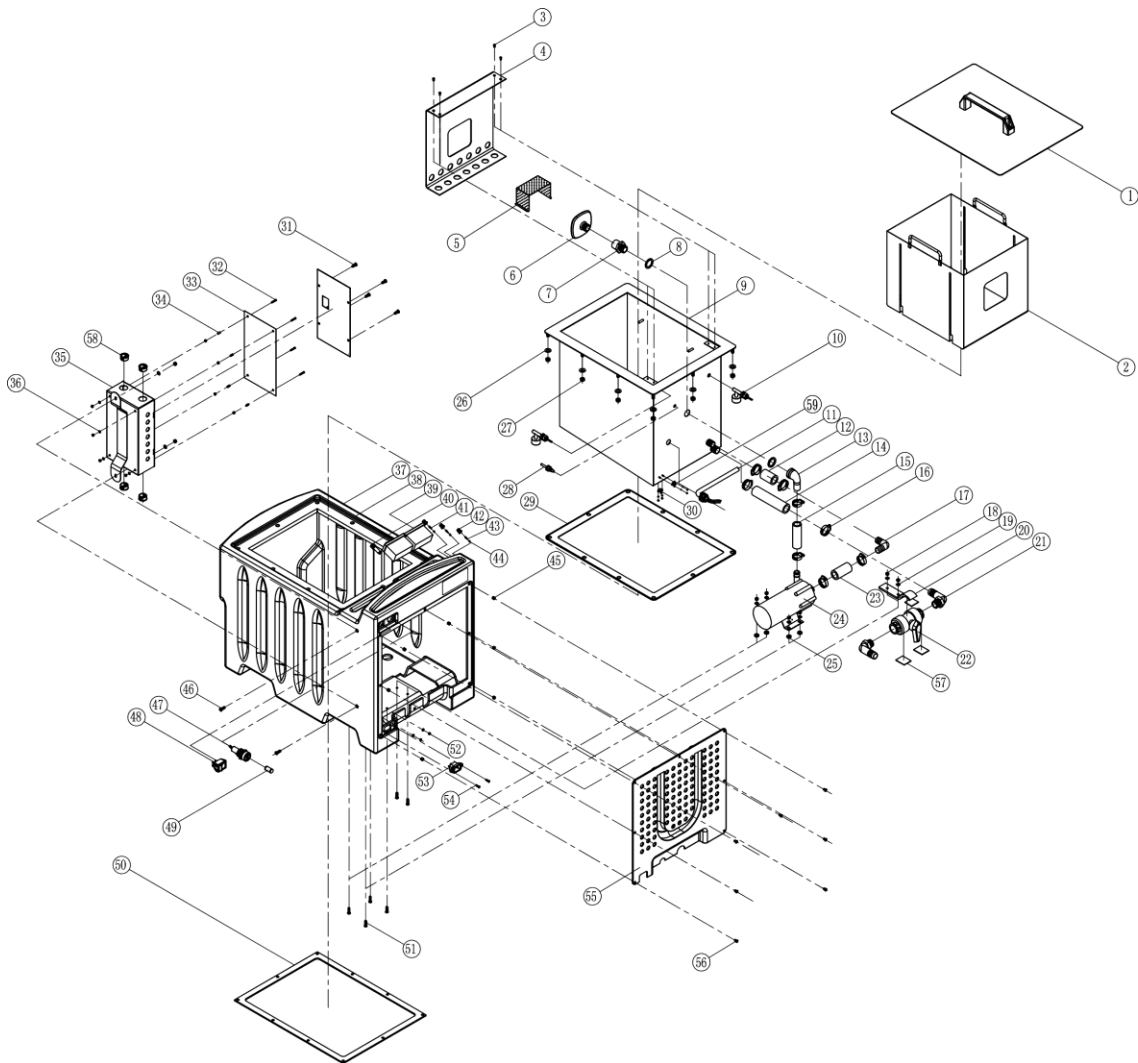

Figure 8: SCA Assembly

Table 1: Parts List of Critical Components

#	Component
1	Lid
2	Basket-Big
5	Strainer
6	Spray Nozzle
10	Level Transducer
11	Heater
22	Valve
24	Pump
37	Body
38	Temperature-Controller
39	Time-Controller
40	Power-Light
48	Power-Switch
49	Fuse
55	Back Cover

6: Unpacking, Inspecting and Installing your SCA

THE SCA SHOULD BE INSTALLED BY AN AUTHORIZED DISTRIBUTOR ONLY. INSTALLATION BY THE USER MAY VOID THE WARRANTY.

Before removing your SCA from its packaging, completely read this manual. Follow all safety recommendations while unpacking, installing and operating the system.

6.1: Package Contents

The SCA is shipped with the following contents:

SCA System (1)	Power Cord:
Large Part Basket (1)	(110V for North America)
Small Part Basket (1)	(220V for Europe/Asia)
Lid (1)	User's Manual & Warranty (1)
Drain Hose, 24 inches (1)	

If any parts are missing you should contact support immediately.

6.2: Unpacking

Place the package on a stable horizontal surface and check inside for the items listed above. Some items may be stored inside the tank for shipping. Remove everything from the SCA unit itself before lifting the SCA from the shipping container.

Two or more people should lift the unit out of the packaging and place it on a table or cart.

6.3: Inspect Unit

Carefully inspect the unit for damage during shipping. If any damage is found DO NOT ATTEMPT TO OPERATE THE UNIT. Contact support immediately for assistance.

6.4: Installation

1. Place the Large Part Basket into the tank, guiding the four cylinders on the tank walls into the corresponding slots on the basket. Gently guide the basket into the tank.
2. Place the lid over the tank to cover it.
3. Attach the power cord to the back of the system and then to a grounded wall socket. Only use a power cord provided by the manufacturer.
4. Turn the power switch to the on position and check to make sure that the display lights up and the Power Indicator is lit.
5. Turn the unit off.
6. Put the drain hose in the storage indentation.
7. Make sure the drain valve is in the closed position.
8. Complete installation checklist and registration form.

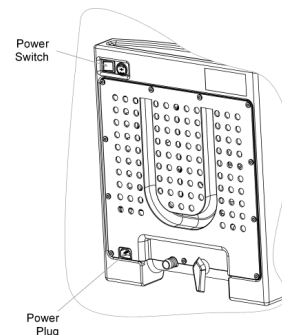

Figure 9: Power Switch and Plug Locations

7: Operating Your SCA

Although the SCA is simple to operate, it is critical that all users follow the instructions in this manual and adhere to all safety guidelines.

7.1: Locating the Unit

The SCA must be placed on a sturdy horizontal surface. There should be no Aluminum or Zinc in the selected location.

THE CLEANING FLUID IN THE SCA REACTS VIOLENTLY WITH ALUMINUM OR ZINC.

The selected location should be isolated from possible contact from those working in the area. It should be near a grounded wall outlet such that the power cord does not pose a hazard to people or equipment passing by.

The power cord plug-in receptacle is a disconnecting device should be easily accessible at all times. Position the unit so that it can be easily reached.

Place the unit in a well ventilated area.

Placing the unit near a drain or sink will make draining the unit much easier.

7.2: Fill the Unit with Water

Place the basket in the tank. Make sure that the drain valve is in the closed position and that the strainer is clean.

Fill the unit up to just below the basket support/guide pins. The tank holds just over 8 Gal (31.5 L). Do not over fill.

Never operate the tank unless the liquid level is above the liquid level low mark on the large part basket or rear wall of the tank.

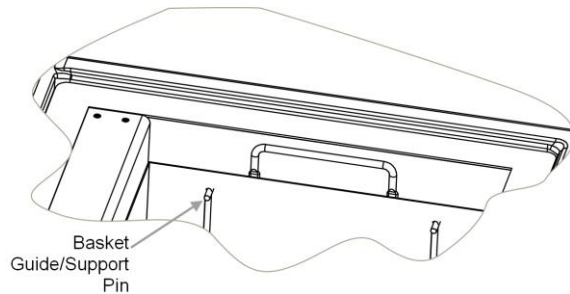

Figure 10: Fill Unit to Just Below Support/Guide Pins

If you plan on running large parts, it is advisable to fill to a lower level to make room for the parts.

To reduce the amount of time required to heat the tank, fill the tank with warm water.

As the parts are cleaned the cleaning solution becomes saturated with the support material and loses its effectiveness. When the liquid turns a “mocha coffee” color, it is time to replace it.

7.3: Add Cleaning Concentrate to the Tank

Wearing protective gloves and proper eye protection, carefully and slowly add in roughly 850 grams of WaterWorks Soluble Concentrate P400SC into the filled tank. Never add concentrate to a tank without water.

7.4: Connect the Unit to Power

Connect the power cord to the back of the unit then to a suitable grounded wall socket.

The unit is compatible with both U.S. 110V~/60Hz and International 220V~/50HZ power. The unit ships with the proper power cord for the country it is shipped to. If

needed, a different cord can be purchased by contacting support. Only use a power cord provided by the manufacturer.

It is strongly recommended that the unit be placed on a circuit with its own breaker with a GFCI. The power circuit must be grounded.

7.5: Turn the Unit On

Press the power on rocker switch on the back of the unit to the on position. The power indicator on the front of the unit should light up.

7.6: Place Parts in Unit for Cleaning

Raise the cleaning basket out of the tank and rest it on the basket support/guide pins.

Place parts to clean in appropriate stainless steel basket.

For smaller parts, open the spring-latched door of the smaller, square basket, place the part(s) inside and place small basket inside larger basket.

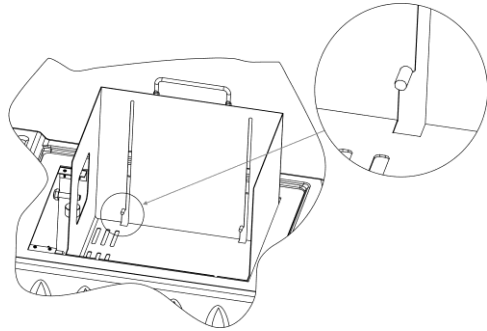

Figure 11: Rest Basket on Support/Guide Pins

Slowly lower the large basket into the tank. Watch the liquid level. If the addition of the parts raises the liquid near the rim of the tank, remove the basket and drain or scoop water from the tank.

7.7: Adjust Liquid Level Before Cleaning and Test Level Sensors

After the part basket(s) are added to the tank, check the liquid level indicators. If the “Low” indicator is lit, add water to the tank until it turns off. If the “High” indicator is lit, scoop or drain water from the tank.

You should always test the level sensors each time you add water to the system. Do this by adding or removing water from or to the tank with a bucket. Using the bucket under and over fill the tank and verify that the level sensor LED’s light up.

Never operate the tank unless the liquid level is above the liquid level low mark on the large part basket or rear wall of the tank.

The system will not run until the liquid level is properly adjusted.

When adding or removing liquid from the tank, always remember that the tank liquid contains cleaning solution. Always use gloves and wear eye protection when adding or removing water from the tank. Never use aluminum or zinc containers.

7.8: Place Lid on Tank

Placing the lid on the tank is not only an important safety precaution, it also improves the system’s efficiency by minimizing heat loss and evaporation.

The lid should only be removed when parts are being added or removed from the tank. Never place your face near the tank when removing the lid, vapors from the cleaning solution may cause eye and respiratory irritation.

7.9: Set System Timer

The pump and heater are controlled by the timer and will only turn on if the timer is counting down. To set the system timer, begin by pressing the Set button on the lower right of the timer display. The last time entered into the system will display and the minutes digits will blink. Press the up and down arrows on the left side of the system to select the proper number of minutes.

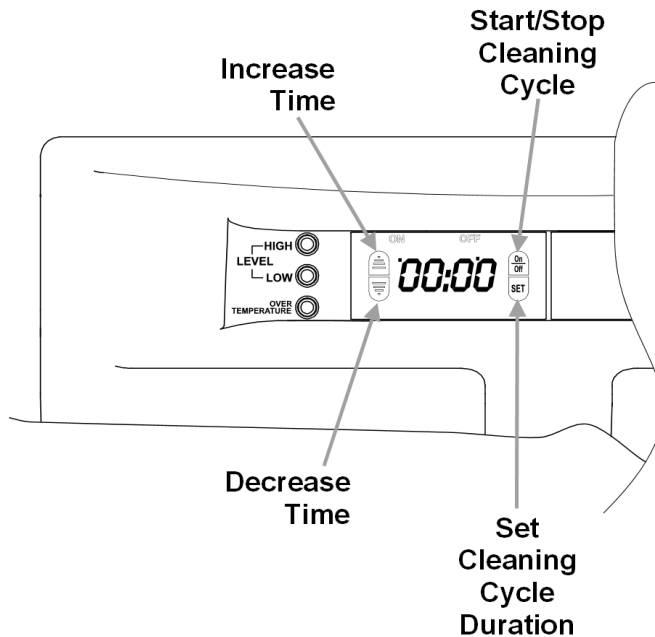

Figure 12: Timer Controls

Press the Set button again to set the hours. The hour digits should now be blinking and you can again use the up and down arrows to set the number of hours that you want. Pressing set again will return to setting the minutes.

When the desired time is shown on the display, proceed to the next step – Start Cleaning Cycle.

Parts can take a few hours to clean, based upon the size of the part, the amount of SST material to be removed, the depth of features that contain support material, and the pH level (alkalinity) of the liquid in the tank. Until some experience is

gained, a cleaning time of four to five hours is recommended.

Additional time can always be added if parts are not completely clean by pressing the On/Off button on the timer, then repeating the process listed above.

7.10: Start Removal Cycle

Before starting the cleaning cycle, make sure that the lid is on the tank.

To start cleaning, press the button marked On/Off on the upper right side of the timer display. This will start the heater and pump, and the timer will begin to count down.

7.11: Monitor Cleaning Cycle

While the cleaning cycle is running, it is important for the user to listen for the alarm buzzer. If the water level gets too low, too high, or if the temperature limit is exceeded, the alarm will sound and both the pump and heater will shut off.

When returning to check on the SCA always check the display panel to make sure the temperature is around 70°C and that the Level or Over Temperature indicators are not lit.

If one of the level indicators are lit, add or remove liquid as required.

If the Over Temperature indicator is lit, or if the temperature is well below 70°C, see the troubleshooting portion of this manual.

Parts can be checked during a cleaning cycle by removing the lid and carefully lifting the Large Part Basket from the tank and resting it on the guide/support pins as shown below. Never place your face near the tank when removing the lid, vapors from the cleaning solution may cause eye and respiratory irritation.

The proper gloves and eyewear should always be worn when lifting the basket from the tank.

If the parts are clean before the end of the cleaning cycle, you can stop the cycle by pressing the On/Off button on the timer.

As the parts are cleaned the cleaning solution becomes saturated with the support material and loses its effectiveness. When the liquid turns a “mocha coffee” color, it is time to replace it.

7.12: Remove Parts from the Unit

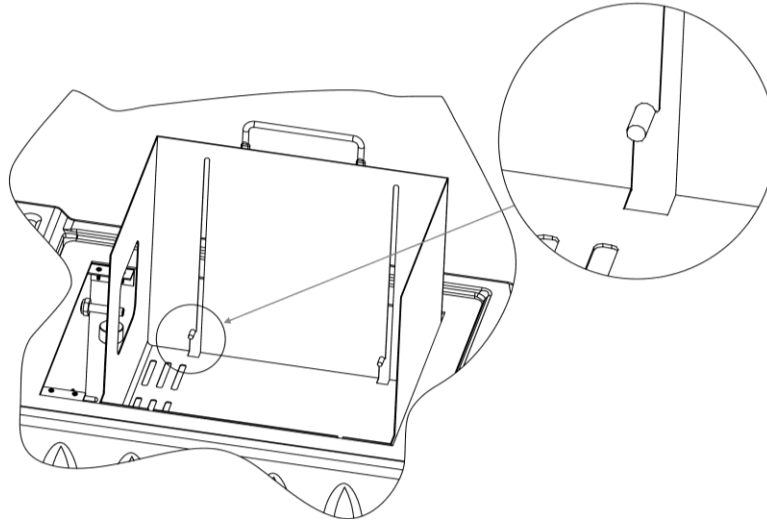

Figure 13: Basket Rests in Tank

Once the cleaning cycle is completed or has been stopped, the parts can be removed from the system. Remove the lid, carefully lift the Part Basket from the tank and rest it on the guide/support pins as shown above. Never place your face near the tank when removing the lid, vapors from the cleaning solution may cause eye and respiratory irritation.

Let the basket rest above the tank for 2-5 minutes to let the liquid drain off of the parts and the basket.

The proper gloves and eyewear should always be worn when lifting the basket from the tank or handling wet parts before they are washed.

Remove the parts and rinse them with water to wash away any residual cleaning solution. Air dry or pat dry with a cloth or paper towels.

Lower the basket into the tank and place the lid on the tank when part removal is completed.

7.13: Turn Unit Off

Once the cleaning cycle is completed and the parts have been removed, the system should be turned off by toggling the power switch on the rear panel to the OFF position.

If the system is not going to be utilized for an extended period, all liquid should be drained from the system and the power cord should be removed from the wall socket.

8: Maintaining Your SCA

As with any piece of equipment, proper maintenance is critical for safety and long life of the SCA.

8.1: Cooling the Tank Liquid

Before draining the tank, make sure that all parts have been removed from the system. If possible, remove the lid to decrease the cooling time as well. Never place your face near the tank when removing the lid, vapors from the cleaning solution may cause eye and respiratory irritation.

Leave the power on to the system to indicate the liquid temperature. Once it has reached 30°C the system can be drained safely.

8.2: Draining the Tank

Never drain the tank unless the fluid is at or below 30°C.

Always wear protective gloves and eyewear when draining the tank.

You should drain the liquid from the tank if the unit will not be used in the near future or if the liquid needs to be changed out because the cleaning solution is saturated with support material.

Make sure that the strainer is in place at the bottom of the tank and that it is clean.

To drain the tank, attach the supplied drain hose to the drain nozzle on the back of the unit. Place the other end of the hose in a floor drain or plastic or stainless steel container that can hold at least 9 gallons of liquid.

Secure the other end of the hose in the drain or container so that it can not come loose during draining.

Turn the drain valve to the “Open” position.

Once the tank is drained, make sure the drain valve is in the “Closed” Position.

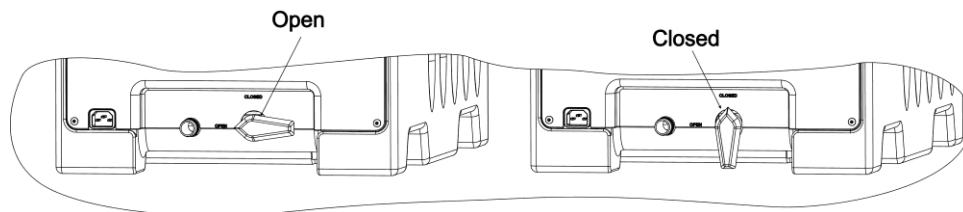

Figure 14: Drain Valve

8.3: Refilling the Tank

Refill the tank and add cleaning solution as described in sections 7.2 and 7.3.

8.4: Inspecting and Cleaning Strainer

The strainer should be cleaned every time the tank is refilled to obtain optimal system performance. You should never remove the strainer when the tank is full of dirty liquid. Doing so will allow debris to get into the pumping circuit and may damage or clog the pump or nozzle. Only remove the strainer if the tank has recently been filled with clean water or if the tank is empty.

The proper gloves and eyewear should always be worn when cleaning and removing the strainer. Never place your face near the tank when removing the lid, vapors from the cleaning solution may cause eye and respiratory irritation.

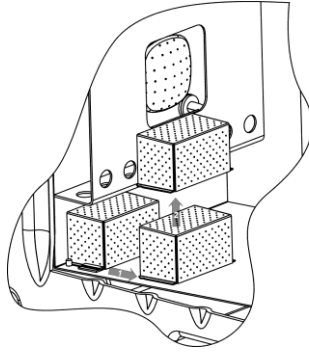

Figure 15: Strainer Removal

To remove the strainer, slide the strainer forward towards the front of the unit until it clears the two sheet metal lips that hold it in place. Once clear, lift the strainer up and out of the tank.

To insert the strainer, slide it along the bottom of the tank towards the rear into the two sheet metal lip. Make sure it is pushed all the way back against the rear wall.

To clean debris from the strainer, scrub it with a nylon brush or a tooth brush and rinse with warm water. Make sure that all holes are unplugged.

8.5: Cleaning

The SCA should only be cleaned with mild soap and water with a sponge or cloth. Never immerse the system or use a spray nozzle or hose to clean it. Any liquid in the electronics area of the system may damage the system and void the warranty. Before using any cleaning or decontamination method except those recommended by the manufacturer, users should check with the manufacturer that the proposed method will not damage the equipment.

8.6: Moving

Always use two people to lift the SCA. The SCA should always be drained before moving. To lift, have each person stand on either side of the unit and place their hands into the indentations under the unit. Lift the unit to a cart or wheeled table for transport.

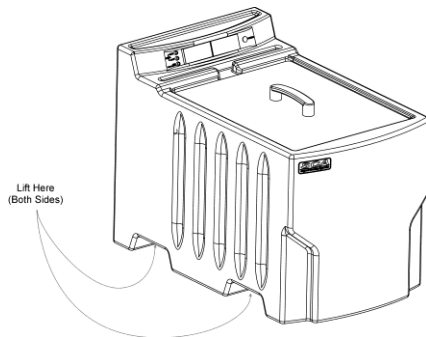

Figure 16: Lifting the Unit

8.7: Replacing the Fuse

You should only replace the fuse with a replacement fuse supplied by the manufacturer. See the Support section of this manual for information on obtaining replacement parts.

Disconnect power to the unit by unplugging the power cord from the wall outlet before replacing the fuse. Then use a Philips head screwdriver to unscrew the fuse cover. Remove the cover and remove the old fuse from the cover and discard. Place a new fuse, supplied by the manufacturer, into the cover. Insert cover into fuse housing and screw in completely. Before reconnecting to power, check to make sure the fuse cap is tight. Reconnect power by plugging the power cord into the wall. Turn on the power using the power switch.

9: Troubleshooting

The SCA has been designed to allow the end user to resolve most operating problems. When a problem is encountered, please read through this troubleshooting section. If a resolution is not found, please visit the on-line troubleshooting guide for additional suggestions. If a resolution is not found there, please contact technical support.

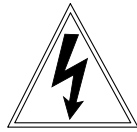

High Risk of Electrical Shock

Always disconnect the unit from power before removing the back panel!

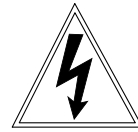

Problem	Probable Causes	What to Do
Power Indicator is not Lit	Power switch is not "On"	Turn rocker switch on the upper-left-hand-corner of back panel to the "On" position. The rocker switch should light up when it is on.
	Power cord is not connected to unit or wall	Check the power cord and make sure it is pushed all the way in to the back of the system and is securely connected to a grounded wall socket
	Fuse is blown	Remove the fuse from the fuse holder and test. If it does not work replace the fuse.
	Power circuit has tripped	Check your building circuit breakers, and any power strips that the unit is plugged in to for a tripped circuit breaker or blown fuse. Reset or replace the breaker or fuse as required.
	Power indicator has failed	If the time and temperature displays are lit, and the power switch on the rear of the unit is lit, the power indicator has probably failed. Contact technical support for assistance in repairing or replacing the indicator.
Pump and heater will not start when the start button is pressed	Power is not on	Check the power indicator on the front control panel. If it is off then proceed to the "Power Indicator is not Lit" Problem.
	Timer has not been set and started	The system will only run when the timer is counting down. Check the timer display on the control panel. <ul style="list-style-type: none"> If it is not counting down, press the On/Off button. If the time being displayed is 00:00, then add time and start the system as described in the "Operating your SCA" portion of this manual.
	Liquid level is too high or too low	Check the indicator lights on the left side of the control panel. If either level indicators is on, add or remove water from the tank until the indicators turns off

Problem	Probable Causes	What to Do
		ALWAYS WEAR PROTECTIVE GLOVES AND EYEWEAR WHEN ADDING OR REMOVING LIQUID FROM THE TANK.
	Liquid temperature is too high	Check the indicator lights on the left side of the control panel. If the over temperature light is on remove the lid and lift the part basket from the tank. ALWAYS WEAR PROTECTIVE GLOVES AND EYEWEAR WHEN MANIPULATING THE PART BASKET. NEVER PLACE YOUR FACE NEAR THE TANK WHEN REMOVING THE LID, VAPORS FROM THE CLEANING SOLUTION MAY CAUSE EYE AND RESPIRATORY IRRITATION. Let the liquid cool and try starting the cycle again. If it overheats a second time, contact technical support.
	Over-temp sensor has tripped	A resettable over temperature sensor located on the back wall of the tank turns off the unit if the temperature of the bath exceeds 90°C. For instructions on resetting this sensor, contact technical support.
	Pump or Heater have failed	Contact technical support.
Buzzer is going off	Liquid level is too high or too low	Check the indicator lights on the left side of the control panel. If either level indicators is on, add or remove water from the tank until the indicators go off ALWAYS WEAR PROTECTIVE GLOVES AND EYEWEAR WHEN ADDING OR REMOVING LIQUID FROM THE TANK.
	Liquid temperature is too high	Check the indicator lights on the left side of the control panel. If the over temperature light is on remove the lid and lift the part basket from the tank. ALWAYS WEAR PROTECTIVE GLOVES AND EYEWEAR WHEN MANIPULATING THE PART BASKET. NEVER PLACE YOUR FACE NEAR THE TANK WHEN REMOVING THE LID, VAPORS FROM THE CLEANING SOLUTION MAY CAUSE EYE AND RESPIRATORY IRRITATION. Let the liquid cool and try starting the cycle again. If it overheats a second time, contact technical support.
Flow in take appears less than normal	Strainer is clogged	Visually inspect strainer. If strainer appears clogged, clean the strainer with a toothbrush without removing the strainer. If necessary, drain the tank and completely clean the strainer. ALWAYS WEAR PROTECTIVE GLOVES AND EYEWEAR WHEN WORKING INSIDE THE TANK.

Problem	Probable Causes	What to Do
	Nozzle is clogged	Drain the tank as instructed in the section “Maintaining your SCA” Remove the nozzle and clean with water. If necessary, clean holes in nozzle with wire brush or small pin. Verify that all nozzle holes are clear before replacing. ALWAYS WEAR PROTECTIVE GLOVES AND EYEWEAR WHEN WORKING INSIDE THE TANK OR HANDLING COMPONENTS THAT ARE COVERED IN CLEANING SOLUTION.
	Pump or tubing is clogged	Contact technical support
Flow from nozzle is not uniform	Nozzle is clogged	Drain the tank as instructed in the section “Maintaining your SCA” Remove the nozzle and clean with water. If necessary, clean holes in nozzle with wire brush or small pin. Verify that all nozzle holes are clear before replacing. ALWAYS WEAR PROTECTIVE GLOVES AND EYEWEAR WHEN WORKING INSIDE THE TANK OR HANDLING COMPONENTS THAT ARE COVERED IN CLEANING SOLUTION.
Liquid has turned a “mocha coffee” color	The cleaning solution is saturated with support material	Drain the tank and add fresh water and fresh cleaning solution as described in the “Operating your SCA” portion of this manual.
Liquid Level indicators did not turn off when liquid was added/removed from the tank	Sensors or Indicators have failed	Contact technical support
System is draining slowly	Strainer is clogged	Clean the strainer with a toothbrush without removing the strainer. ALWAYS WEAR PROTECTIVE GLOVES AND EYEWEAR WHEN WORKING INSIDE THE TANK. Resume draining. Do not drain without the strainer, this may cause significant harm to the pump head and void the warranty.

10: Technical Specifications

Item	Specification	
	SCA-1200	SCA-1200
Model Number	SCA-1200	SCA-1200
Power Cord	110 North American	220 International
Power Requirements	100-120V~ 60 Hz 15A	220-240V~ 50 Hz 10A
Electrical Protection	15 Amp Fuse	10 Amp Fuse
Heater Power	1,300 Watts	1,700 Watts
Certification	CE – See www.DimensionSCA.com for specifics	
Tank Capacity	8.3 Gallons / 31.5 Liters	
Physical Dimensions	16 x 19 x 26.5 inches / 41 x 48 x 67 cm	
Shipping Package Dimensions	30.25 x 20 x 23 inches / 76.9 x 51.0 x 58.3 cm	
Weight, Shipping Max	NW: 66.7 lbs / 30.25 kg	GW: 70.6 lbs / 32 kg
Large Parts Basket Capacity	10 x 10 x 12 inches / 25 x 25 x 30 cm	
Small Parts Basket Capacity	4 x 4 x 4 inches / 10 x 10 x 10 cm	
Allowable Temperature Range	10°C - 70°C	
Temperature Control Accuracy	± 2°C	
Pump Max Flow Rate	8 GPM / 30 LPM	
Acoustic Noise Level	< 50 dB @ 1 meter	
Temperature Display	Digital LED Readout	
Timer Display	Digital LED Readout	
Liquid Level Checking	Fixed liquid level sensors with separate lamp indicators for high and low level and 3 min. audible alarm for both.	
Temperature Checking	Over temperature sensor, factory set at 70°C. 3 min. audible alarm and lamp indicator.	
Pump and Heater Safety Lockouts	Low liquid level, high liquid level, over temperature, no time on timer.	
Tank Construction	Welded Stainless Steel Sheet	

Specifications are subject to change without notice.

11: Technical Support

Technical support for this product is provided by Phoenix Analysis & Design Technologies, Inc. (PADT). Before contacting technical support please do the following:

1. Try the Troubleshooting table in this manual.
2. Visit **www.DimensionSCA.com/support** and try the troubleshooting found there.
3. Write down your model number and serial number (found on the back of the unit).

If the unit is under warranty or covered by a maintenance contract, contact the Authorized Reseller from whom the unit was purchased.

Otherwise, to receive technical support, visit **www.DimensionSCA.com/support** and proceed to the “Request Technical Support” page and fill out the support request form there.

If you prefer to e-mail, you can send an e-mail to: support@DimensionSCA.com. Please include your full name, company name, phone number and product serial number in all e-mails.

If you prefer to call, dial: 1-800-293-PADT and ask for SCA technical support.

11.1: Replacement Parts

Visit **www.DimensionSCA.com** or call 1-800-293-PADT for information on obtaining replacement parts.